



Installation Instructions



Note: Please read this document before beginning installation.

If you are not confident with the processes involved, please hire a general contractor to install your flooring according to these specifications. Proper installation is a requirement of the StableComfort™ warranty.

*Contact head office for more information at **888-337-6265**.*

Installation Instructions

YOU WILL NEED:

- Mattresses, cover and strips provided by Promat Inc.
- Fasteners for your system (not supplied), every 6-8 inches, based on stall wall and doorway material (wood, steel, concrete).
- Utility knife, drill for above fasteners, black caulking (optional).

GROUND PREPARATION

- The ground in the stall where the mattress is being installed must be level or even slightly domed in the middle.
- Concrete or Asphalt stalls are probably already level but make sure that any holes or problem areas are fixed.
- If you have an earth or gravel based stall, chances are some work is needed.
- It is essential that the stall is not dipped to the middle or bowl shaped.

DOMING (OPTIONAL, BASED ON PREFERENCE)

- You may also want to dome or crown the floor, so the urine will run away from the horse and centre of the stall towards the outer edges. The horse spends the majority of its time in the middle of the stall, so doming allows for ground and mattress compaction.
- If you are doming, we recommend the middle of the stall be approximately 2" higher than the outer edge.

FILLING WITH AGGREGATES

- If the stall is too low, bring in some gravel to fill and level
- Recommended aggregates are pea gravel, $\frac{3}{4}$ washed stone or even "A" gravel or also known as road gravel. These materials need little packing and will resist settling over time.
- Sand is not recommended because it doesn't pack well and has a tendency to shift and move.
- No matter what fill is used, it will require watering down and/or packing with a tamping device.

CAUTION! If the aggregates are not packed with water and/or a tamping device and they settle, it will result in premature stretching and perhaps wrinkling of the top cover.

- The StableComfort™ system is approximately 2.5" high, so be sure to plan whether you wish your flooring to be level with the aisle or lower/higher than the aisle. This is a choice based on personal preference.
- If the stall does not have a threshold at the door, use a pressure treated 4x4 and fasten it to the posts of the stall, level with the aisle way.

- Bring in the fill, level it, (*if doming, keeping the centre of the stall slightly higher*) and compact it using water and/or a compacting machine.

PREPARING THE MATTRESS LAYER

- Each stall is unique, and your StableComfort™ mattress count has been specifically calculated for you. If you do not know how many mattresses were supplied for each stall, be sure to double-check with your sales representative. It is important to ensure all of the supplied mattresses are used in the installation, as it is a prerequisite for warranty validation.
- Measure the stall and the mattresses to determine the most effective way to lay each mattress.
- Starting in one corner, bring in the first mattress. The labeled end of the mattress should lie in the middle of the stall.
- Lay the mattress down tight to the wall. The mattress should lay approximately 46” wide. It is important to ensure there are no gaps between the mattresses while installing.

CUSTOMIZING THE MATTRESS LAYER

- Before making any cuts, ensure the bottom layer has been filled and the cells tight against each other along the entire bottom layer of the stall. It is not possible to repair a mattress cell once it has been cut.
- If the mattress is too wide (too many cells to fit the mattress layer), you may trim individual cells of the mattress in one easy step. Cut lengthwise down the centre of the first cell which is unable to fit the mattress layer. Cut only the top layer of fabric, spilling the inner rubber crumb on top of the bottom layer of mattresses. Finish cutting through the bottom layer of fabric, which will release the remaining extra mattress cells from the mattress layer.
- If the mattress is too long, create a “T” cut at the top end of the cell(s). Cut along the edge of the mattress, then remove the extra excess rubber crumb from the cell (keep this crumb on top of the mattresses as fill for the next step). Fold the excess mattress material tightly under the remaining mattress. This will stop the rubber from flowing out at the newly cut end.

RUBBER CRUMB FILL

- The cellular design of the StableComfort™ mattress ensures minimal movement of the rubber crumb. Loose rubber crumb is used to fill the ribs in the mattresses where the stitching is, to prevent the top cover from developing ripples over time.
- Be sure that the crumb is evenly spread and leveled. If you are unsure how many mattresses you have been given per stall (how many on the bottom layer and how many for extra rubber crumb), please contact your sales representative.
- The labeled end of the mattress is less full, so ensure to cover this area with rubber crumb first, then spread around.



Two mattresses joined together. All gaps are filled with loose rubber crumb from cutting up cells of a mattress.

- It is best to lay all of your mattresses in a similar direction, if possible. If your stall dimensions work out better to run the mattress in different directions, this is acceptable, but remember to fill all junctions with loose rubber to ensure a level surface.

TOP COVER INSTALLATION

- Now that the mattresses are laid and loose crumb is evenly spread, the top cover can be brought in and unrolled **rubber-coated side up**.
- Move around the cover so that there is at least 4" going up each wall and that the cover is square in the stall.
- Crease the top cover by stepping down where it meets the wall. This forms a 90-degree edge, which is easier to work with for the remainder of the installation, and will also provide a nicer finished look to the flooring.
- Make sure that the cover lays flat without wrinkles or air bubbles.



- The StableComfort™ top cover comes in a large "carpet" roll, manufactured at 12'8" wide (unless you have a seamed top cover). Remember the length direction and the width direction of the roll, as you lay out the cover. If you are unsure of how to lay your top cover most effectively, remember that you require at least 4" of cover on each wall for fastening.

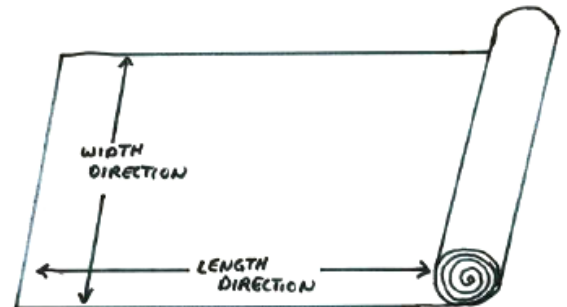

PREPARING TO FASTEN

This is the beginning of the final part of the installation, but it is the most integral and important part! An error at this point of the installation could affect the performance of the product.

- Make sure to have a good sharp knife and replacement blades, as needed. Centre the cover in the stall.
- The top cover is designed to have more stretch in the length direction. Prior to any fastening, stretch the material in the length direction as much as possible. Stretching the cover will not be effective if one of the walls corresponding with the length of the roll is already fastened.

THE FIRST TWO CORNERS

- Prepare to fasten the width direction first (the 12'8" wide unless seamed). Prior to fastening along the length of the wall, you must prepare both corners. You will create two "wings", and then fold one behind the other.

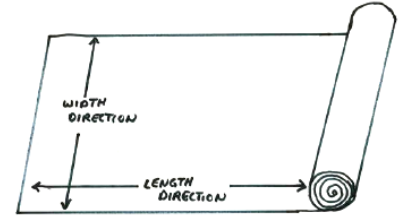

CAUTION! A slip of the knife could make the cover too small for the stall or cause quality concerns. Do not cut too far down into the corner.

The pictures below show how to cut the corners:

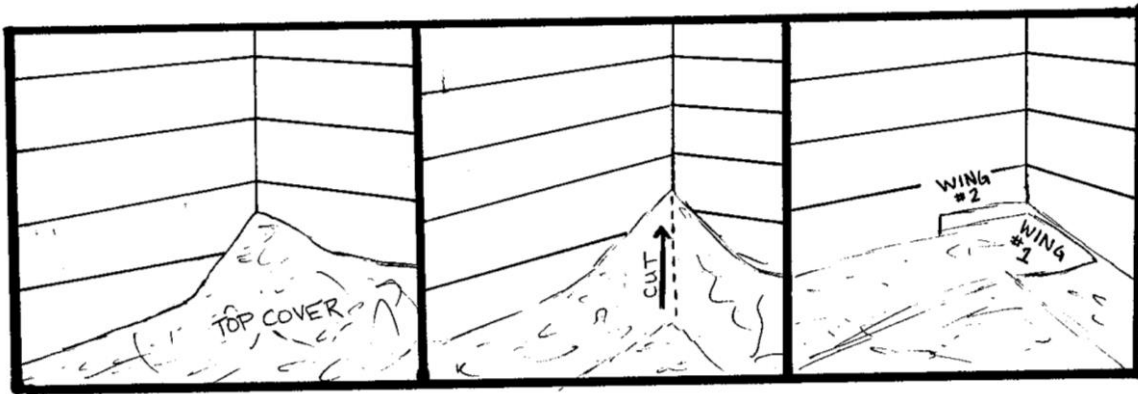

- Press the cover into the corner, stepping to crease it where the floor meets the stall wall.
- Start with your knife tip at the intersection of the floor and corner of the walls, and cut a slit in the top cover by slicing upwards vertically along the corner. This cut will create two separate wings of the cover at the corner.
- Next, fold the wings one behind the other and lie them flat against the stall walls, ready for fastening.
- Cut the corner of the same wall the same way, but do not cut the rest of the corners until you are ready to fasten the strips against the wall. You should have two corners cut and folded, with one section of wall in between.

FASTENING THE PLASTIC STRIP

- Measure the length of the wall from corner to corner. Cut the plastic strip to cover this length. If the wall is longer than 10', more than one section of plastic strip will be used. The easiest way to cut the plastic strip to score it a few times with a sharp knife, and then snap the strip in two by bending it backwards at the scored area.
- Begin fastening the plastic strip against the top cover. When the strip is finished, it will be fastened every 6-8", as well as at the beginning and end of each strip.
- The plastic strip acts as a large washer to help hold the cover.

OVERVIEW: For best overall function and appearance, fasten the first screw exactly halfway up the strip, close to the far edge of the strip. Next, fasten the top row of screws approximately 12" apart, followed by the bottom row of screws approximately 12" apart, staggered with the top row. Finish the strip by fastening the final screw exactly halfway up the strip, close to the far edge.

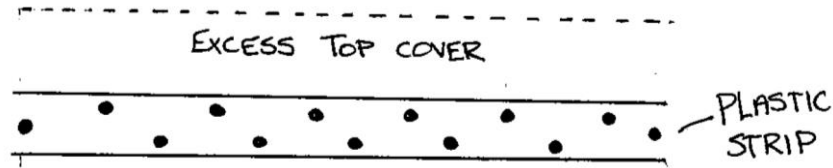

- The best way to draw the cover tight is to keep the base of the strip slightly away from the wall while the top edge of the strip lies against the wall (see diagram below). This allows the strip to assist in stretching the cover when the second row of screws is fastened. (The plastic strip does not need to be pre-drilled)

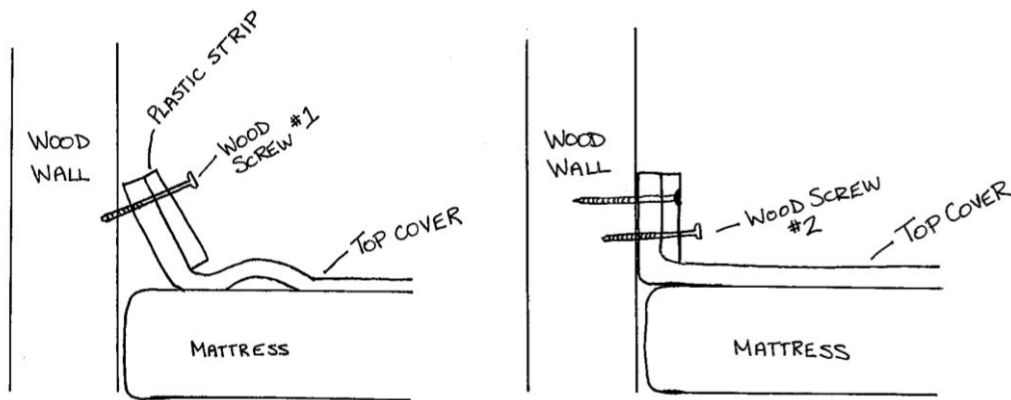

FASTENING HARDWARE

- For wooden stall walls, a coated or stainless steel 1 $\frac{3}{4}$ " screw is recommended, so that over time the screws do not corrode, making them hard to remove.
- To fasten to any other type of wall material, contact your local hardware store for the best fastening hardware.

FASTENING DETAILS

- The tighter you can stretch the top cover in both the length and width direction, the less chance of future stretching there will be.
- Keep the strip level and running along the wall rested immediately above the mattress level. If the strip rides up the wall too much, the cover will be on angle, meaning that if the horse steps in that area, it could tear the cover because there is nothing behind it.
- Do not work from the two ends of the wall to the middle. Start at one end of the wall and carry on to the other end, first fastening the top row, then the bottom row, and finally the finishing screw.
- The diagram shows us an example view of a stall floor:

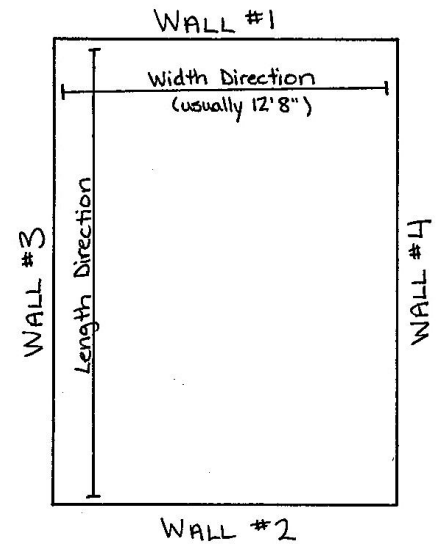

When fastening strips, start on wall # 1, then wall # 2, then wall # 3 and last wall # 4.

Always fasten the walls across from each other.

- Once all of the strips are fastened, cut all of the excess top cover along the top of the strip with a sharp knife. This will give a clean, finished look to the cover.

FASTENING AROUND POSTS AND OTHER OBJECTS

- In case there are posts/feeders/etc, you may have to cut the cover and strips. Cut the cover down along the edge of the obstacle until you reach the mattress. Do not puncture the cell of the mattress, if at all possible. Let the cut part of cover fall back against the wall and do the same with the other side of the post. Fasten with the strips along all sides to ensure every edge is fastened.
- Cut all the excess top cover along the top with a sharp knife once all the strips are fastened.

FASTENING AT DOORWAYS

- At the doorway there usually is a concrete or wooden threshold.
- When fastening into a concrete floor use either concrete screws or concrete nails, no shorter than 2". A tap con into a predrilled hole is usually the most effective.
- Fasten the cover down over the mattress. There will be a slight step up (see diagram).
- Another solution is to fasten a board to the concrete first across the doorway and then fasten the top

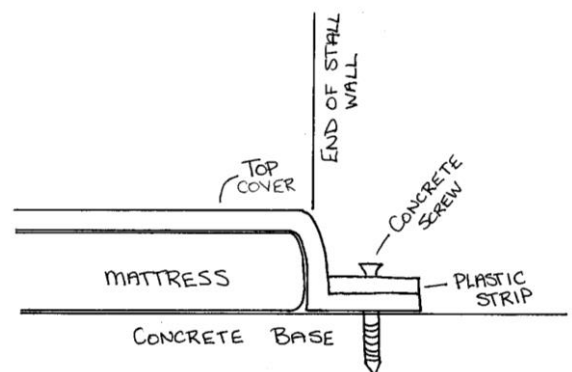

cover down to the board.

WHEN YOU CANNOT FASTEN TO THE STALL WALL

- In some stalls, it is not possible to fasten to the stall walls, or there are removable stall walls.

SOLUTION #1

- If the top cover cannot be fastened to the wall because its composition (concrete, steel etc.) the first solution to consider is to fasten a board to the wall using the appropriate screws or bolts. Then fasten the top cover to the board.
- It is often possible to lay a wooden perimeter out of pressure treated 4x4.
- Lay the mattresses flush with perimeter and fasten the top cover down to the wood.

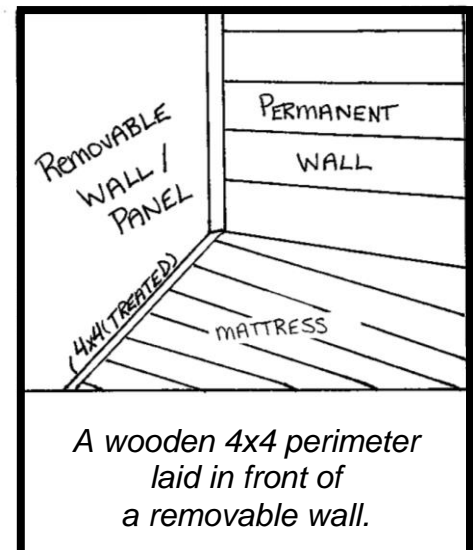
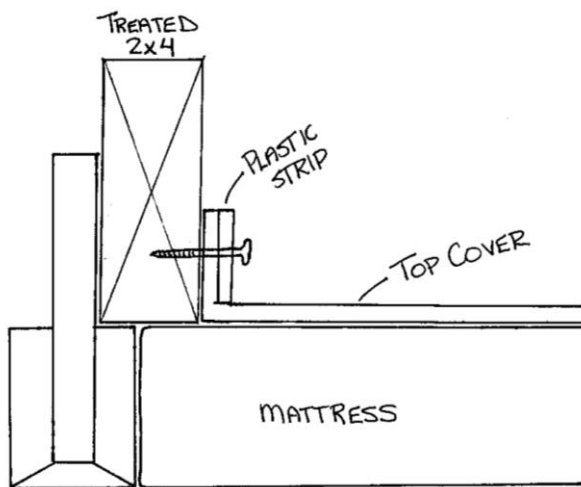

SOLUTION #2

- Fastening to a concrete curb that the stall walls rest on requires the use of many concrete screws or nails. This method could also be used if the wall rests on wooden footing. Installation would be easier if a 2x4 was fastened to the concrete curb, and the plastic strip was then fastened to the 2x4. Note the difference in method depending on the curb depth.

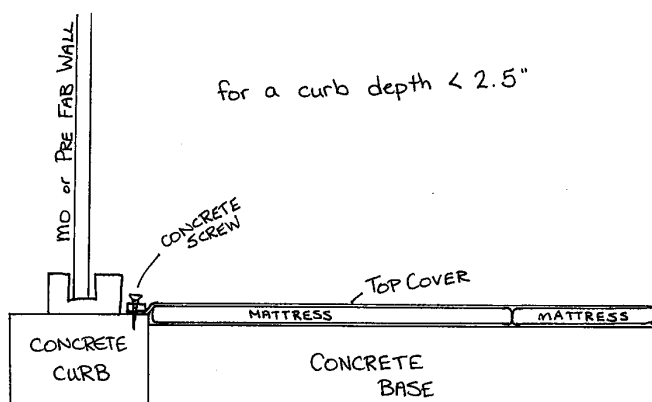

7

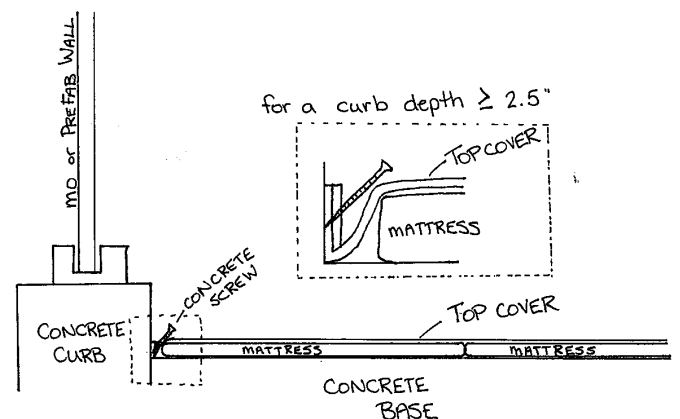

StableComfort™ Best Practices: A Finishing Touch

- To promote the 100% waterproof characteristic of the StableComfort™ flooring system, it is a common practice to line the top of the fabric cover/plastic strip along each wall with a bead of black caulking or similar product. This will ensure the edge of the cover along the wall is also waterproof, similar to the entire surface of the top cover.

StableComfort™ Best Practices: Bedding

- Bedding varies from place to place, and is based on the needs of the horse.
- StableComfort™ requires a small amount of absorbent bedding to keep the stall dry.
- Bed where the horse urinates. There is enough comfort built into the system, and the bedding is required only to soak up the urine.
 - For mares, bed where they urinate.
 - For geldings and stallions, put a pile of bedding in the middle of stall. They will move it around and make their own bed.

StableComfort™ Best Practices: Maintenance

- The only maintenance aspect regarding to StableComfort™ is that in some stalls the top cover might stretch and may become looser over time.
 - This begins as merely an appearance problem, but if it goes too far unresolved, it could cause premature wear on the top cover.
 - Fixing is easy. Remove the plastic strips where the stretch is, on 3 walls only, remembering that it is easiest to stretch the length direction of the cover.
 - Draw the cover tight and refasten the plastic strips as instructed in the above sections.
 - Cut off the excess cover.

StableComfort™ Best Practices: Cleaning

- Using a mop & bucket (and hose if desired), StableComfort™ can be cleaned and disinfected with a diluted 5% bleach-to-water ratio.
- The only other acceptable cleaning compound is Stable Boy by Sanimax, which stops bacterial growth and restricts odour-generating bacterial for an extended period of time. Call Sanimax directly at 800-263-7430 for product and pricing information.

